

► **IKO GUIDE**

# THIS IS HOW YOU CHOOSE AND INSTALL THE BITUMINOUS CAP SHEET FOR FLAT ROOFS

Where an underlay makes the connection between the insulation and the waterproofing, the top layer is the final protection against weather conditions and other external factors. There is a wide range of choices.

This guide will help you determine the right roof structure.

What factors should you take into consideration when determining the top layer?

What are the installation conditions for this top layer?



# BITUMINOUS TOP LAYER

**A suitable top layer demands the necessary attention, as this is also essential for:**

- reliable dual-layer waterproofing
- improved penetration resistance (better mechanical properties)
- protection against root growth
- protecting the building against flying fire
- rainwater recovery
- the efficiency of technical installations on the roof
- reducing thermal tension in the roof structure
- the contribution to the environment through air purification and reflection
- the aesthetic finish of the roof
- the insured guarantee on the roof structure

## 1 - Design

**Bituminous waterproofing is the most effective when a dual-layer torched implementation is used, because:**

- The melting creates outstanding adhesion between the top layer and the underlay.
- The seam joint benefits from the highest durability, with no use being made of external adhesives.
- The top layer melts together with the underlay, forming outstanding waterproofing with a thickness of 7 to 8 mm, leaving only a scant risk of perforation

**When choosing the top layer, the following aspects should be taken into account:**

### 1.1 - Protection against root growth

On roofs that include growth or are susceptible to undesired growth, it is preferable to provide a root-resistant top layer. The following roofs fall into this category:

- Green roofs
- Terrace roofs
- Gravel ballast roofs

Roofs that include tiles (on tile supports) or another form of ballast (such as gravel) are more sensitive to undesired growth through dirt in hard-to-reach areas. This is why a root-resistant top layer is also recommended for these roof structures.

When implementing a roof garden, a distinction is drawn between intensive (bushes, grasses, trees, etc.) and extensive (weeds, sedum, etc.) growth. For extensive growth, a root-resistant roofing membrane is sufficient to protect the roof against root growth. In the case of intensive growth, additional protective measures should be taken.

Always consult the technical datasheet for the roof waterproofing for root-resistant properties (EN 13948).

### 1.2 - Protection against flying fire

Another important function of the top layer is to protect the roof and the building below against fire from outside. The IKO premium top layers meet Broof (t1-t4), whereas most standard top layers only meet Broof (t1).



### 1.3 - Rainwater recovery

IKO's bituminous roofing membranes are suitable for rainwater recovery. This is confirmed by recognised independent laboratories (WTCB and T.A.U.W.).

### 1.4 - Reflection: efficiency of technical installations and passive cooling

When fitting technical installations on the roof, a reflective roof covering has a positive effect on efficiency. The surface temperature on the flat roof is sufficiently reduced in particular, with the result that solar panels and HVAC installations can function more efficiently.

### 1.5 - Ecology: air purification

A top layer can also take care of neutralising harmful substances, such as nitrogen oxides and sulphur oxides. In this case, the granulate on the top layer includes a unique substance known as titanium dioxide (TiO<sub>2</sub>). This active substance brings about a demonstrable and permanent improvement in the air quality.

### 1.6 - Vapour pressure distribution

In the case of a roof renovation where only the waterproofing is being overlaid, you should top for a top layer with an underside that distributes vapour pressure. We refer to the Guide "All you need to know about the bituminous underlay" for this.

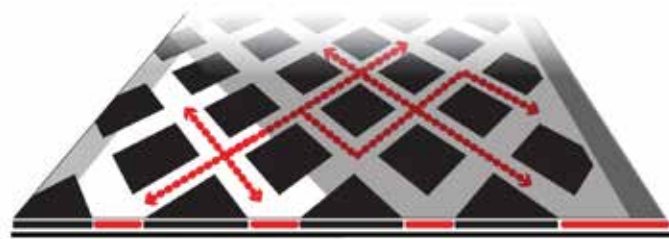

- = overlap (does not interrupt the vapour pressure distribution)
- = vapour pressure distribution
- = partial adhesion to existing bituminous membrane

### 1.7 - Guarantee

When choosing a top layer, it is important to take the guarantee provisions into consideration as well. Indeed, most manufacturers offer a formula for a waterproof insured guarantee. The contents of this type of guarantee can vary significantly between suppliers, however. IKO offers a unique all-in insured waterproof guarantee, which covers the liability of the various parties in the construction process from the design phase up to ten years after delivery. Even consequential damage and implementation errors are included in this guarantee.

### 1.8 - Fixing method

The attachment of the top layer determines the type of membrane that can be fitted.

Fixing method	Top layer characteristic
Torching (partial / full)	Underside thermofusible film
Cold adhesion	Micro-perforations / tallow finish
Mechanical attachment	Wider overlap (12 cm)

The implementation and accompanying choice of product will be discussed further in the next sections.

## 2 - Implementation

### 2.1 - Transport and storage

- The rolls should always be stacked upright, including during installation on the roof.
- It is advisable to fit the top layer and any self-adhesive underlay simultaneously, especially in cold weather.
- Collect the packaging together and preferably have this collected by a recycling firm.

### 2.2 - Installation

For high-quality dual-layer waterproofing, the top layer should preferably be applied through full torching. Only then will the top layer and the underlay form a single whole, with outstanding waterproofing and wind resistance as a result.

#### 2.2.1 - General guidelines

- The base should be level, dry, clean and free from grease and dust.
- In order to obtain a good welded seam joint, a bitumen track of  $\geq 5$  mm must always flow out at the overlap.
- Remove wrappers from the roll before fitting.
- Always fit the top layer in the same direction as the underlay.
- T-seams at end overlaps can be avoided by cutting the corner away

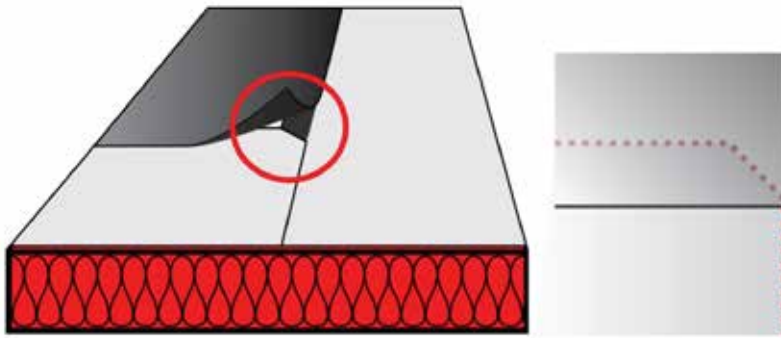

- The top layer is fitted in half-brick bond with a minimum distance of 2 metres between the cross overlaps.
- Avoid standing seams at the level of the cross and lengthways overlaps to limit water stagnation.
- Always position the top layer perpendicular to the underlay. In both the crossways and lengthways direction. The top layer overlap should preferably be staggered by half the width of the membrane in relation to the underlay overlap. This is how to get the best waterproofing result

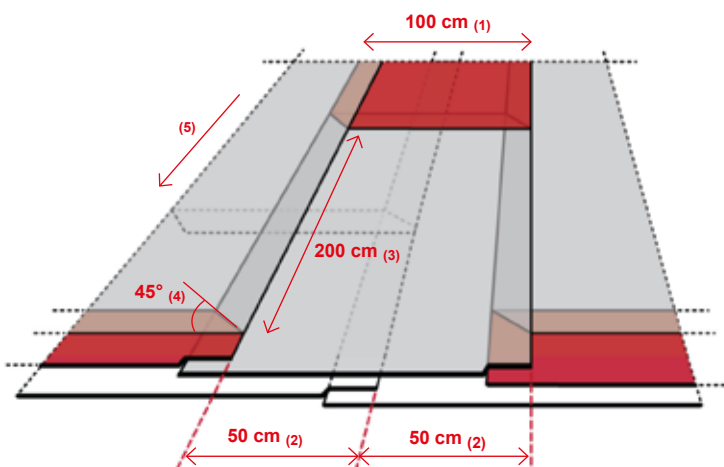

- 1 - Waterproofing roll width
- 2 - Perpendicular positioning of top layer in relation to underlay (half width)
- 3 - Minimum distance between cross overlaps
- 4 - Corner bevelling against capillarity
- 5 - Advised drainage direction for this laying pattern (without standing seam in the overlap)

### 2.2.2 - Torched top layer

- The rolls are fitted in half-brick bond in the sense of drainage.
- The membrane is welded to the base with an overlap of 8 cm in the lengthways direction and 15 cm in the crossways direction. All the details will be implemented in accordance with the Technical Information no. 215 and 244 from the BBRI.
- The soft flame of the asphalt burner will be about 2/3 directed at the roll itself and about 1/3 at the base during the welding, such that there is always a bitumen track present in front of the roll.
- In the case of single-layer waterproofing, the seam joints should be carefully implemented, with extra checks.
- The gutter zones and all the details, edge finishings, expansion joints, downpipe covers, skylight fixtures, drainage etc. must always be implemented in dual layers.
- The fixtures are also equipped with dual-layer waterproofing by means of vertical edge strips 1 metre wide. The membrane at the level of the raised edge is fitted perpendicular to the membrane in the roof surface. The underlay is attached with the method adapted to the base present, but sufficiently wind-stable according to the wind resistance requirements of the Technical Information no. 215 and 239 from the BBRI.

### 2.2.3 - Mechanically attached top layer

- The rolls are fitted in half-brick bond in the sense of drainage.
- The membrane is mechanically attached to the base with adapted screws and pressure distribution plates that are suitable for the mechanical attachment of bituminous membranes on the roof structure present.
- The membrane is fitted to the base with an overlap of 12 cm in the lengthways direction and 15 cm in the crossways direction. All the details will be implemented in accordance with the Technical Information no. 215 and 244 from the BBRI.
- The number of screws in the middle, corner and edge zones will be determined by the wind load on the roof (see Technical Information no. 239 from the BBRI – Belgian Building Research Institute) and the useful wind resistance of the screws.
- In the case of single-layer waterproofing, the seam joints should be carefully implemented, with extra checks.
- The gutter zones and all the details, edge finishings, expansion joints, downpipe covers, skylight fixtures, drainage etc. must always be implemented in dual layers.
- The fixtures are also equipped with dual-layer waterproofing by means of vertical edge strips 1 metre wide. The membrane at the level of the raised edge is fitted perpendicular to the membrane in the roof surface. The underlay is attached with the method adapted to the base present, but sufficiently wind-stable according to the wind resistance requirements of the Technical Information no. 215 and 239 from the BBRI.

### 2.2.4 - Cold-glued top layer

- The rolls are fitted in half-brick bond in the sense of drainage.
- The first roofing membrane is unrolled and aligned, and then rolled back up to around half the length.
- The sides of the roofing membrane are outlined on the underlay.
- After rolling it back up, the cold glue is applied with a squeegee within the outlined zone, after which the roofing membrane is unrolled into the glue.
- Cold glue consumption in line with the manufacturer's guidelines.
- The next roofing membrane is fitted in the same manner. The cross overlap ( $\geq 15$  cm) and lengthways ( $\geq 8$  cm) overlap are welded with a hot-air gun or soft flame. All the details will be implemented in accordance with the Technical Information no. 215 and 244 from the BBRI.
- Overlaps and fixtures cannot be cold-glued. In case of any doubt, consult your IKO advisor.
- The gutter zones and all the details, edge finishings, expansion joints, downpipe covers, skylight fixtures, drainage etc. must always be implemented in dual layers.
- The fixtures are also equipped with dual-layer waterproofing by means of vertical edge strips 1 metre wide. The membrane at the level of the raised edge is fitted perpendicular to the membrane in the roof surface. The underlay is attached with the method adapted to the base present, but sufficiently wind-stable according to the wind resistance requirements of the Technical Information no. 215 and 239 from the BBRI.

### 3 - Choice of top layers

Top layer advised for specific roof functions				
Roof function	Property of top layer	Specification	Type of top layer	Aesthetic finish of top layer
Green roof Terrace roof Ballast roof	Root-resistant	FLL / EN 13948	IKO carbon 250 IKO roofgarden	Black granulate Thermofusible film
PV roof Technical installations	Reflective	Solar Reflectance Index (SRI 79)	IKO carrara	White granulate
Ecological roof	Air-purifying Cooling Recycling	Titanium dioxide (TiO <sub>2</sub> )	IKO carrara	White granulate

Top layer advised with specific properties			
Property	Specification	Designation	Aesthetic finish of top layer
Fire safety (Resistance to flying fire)	Broof (t1-t4)	IKO carbon 250 IKO carrara IKO pantera IKO powerflex Tecno G	Black granulate White granulate Black granulate Dark-grey slate chippings
Root resistance	FLL	IKO carbon 250 IKO roofgarden	Black granulate Grey slate chippings or sand
Air purification	Titanium dioxide	IKO carrara	White granulate
Heat reflection	SRI 82	IKO carrara	White granulate

Top layer advised in line with the fixing method			
Fixing method	Property of top layer	Type of top layer	Aesthetic finish of top layer
Mechanical	Overlap width 12 cm IKO powerflex Tecno (G) IKO powerflex mono3 MB	IKO carrara Tecno Dark slate chippings Black granulate	White granulate
Cold-glued	Bottom finish with tallow or micro-perforations	IKO powergum 4 AD/MMP	Dark slate chippings
Torching (full)	Bottom finish with thermofusible film	IKO carbon (250) IKO carrara IKO pantera IKO powergum IKO powerflex	Black granulate White granulate Black granulate Dark / light slate chippings Dark / light / white slate chippings
Torching (partial) → for roof renovation without additional insulation	Bottom finish with thermofusible film and Quadra diamond tread	IKO carrara Quadra IKO powerflex Quadra IKO powergum Quadra	White granulate Black granulate Dark / light slate chippings

## COLLECT ALL OUR IKO GUIDES!!

**This Guide is a document in the IKO Guides series.**

With these documents IKO aims to highlight the various technical aspects of flat roofs that are important to Architects and Roofers.

We draw on both our expertise and manufacturing experience in relation to bituminous waterproofing, insulation and liquid waterproofing to produce this series of guides, and we are pleased to have this opportunity to share our flat roof knowledge with you. Above all, they seek to defend a pragmatic quality philosophy with attention to detail which will benefit clients and roof professionals alike.

All of our **Guides** can be collected to form a complete volume that you can refer to for years to come, and they are also available to view online on the IKO website. Our Guides series will be regularly updated with new and useful materials.



This document has been drawn up to the best of IKO's ability, taking into account the technical knowledge and experience, without providing assurance regarding any hidden elements, and without taking into account technologies not yet sufficiently tested on the date of this document being drawn up. By drawing up this document, IKO is never under any obligation to produce results. At no time can the present document engage the liability of IKO. For specific advice, always consult your IKO advisor.



*Want to read online?  
Scan here!*



**ROOFING | WATERPROOFING | INSULATION**

IKO nv - d'Herbouvillekaai 80 - 2020 Antwerp - Belgium - +32 3 248 30 00 - <https://be.iko.com>

